

July 9, 2012

CSA Z32 – TESTING GUIDELINE AND PROCEDURES

This document is intended to outline the various tests, procedures and preparations required to perform a successful CSA Z32 test. The code references noted refer to Canadian Standards Association Z32 – 09, “Electrical Safety and Essential Electrical Systems in Health Care Facilities”. This guide is not intended to be a detailed wiring reference or contractor field guide. Refer to your specific facility design drawings and specifications for further installation details.

FACILITIES REQUIRED TO MEET CSA Z32:

According to the Alberta Building Code STANDATA CEC-24 “Canadian Electrical Code, Section 24 – Patient Care Areas”:

“Section 24 rules are to be applied to health care facilities beyond the traditional hospital locations including but not limited to dental clinics, physician’s offices, and chiropractic clinics.

Contractors should reference CAN/CSA-Z32 and consult with the facility practitioners, or the licensing body to determine the different patient care areas in a facility, when these areas have not been designated by an engineer”

CSA Z-32 refers to the following areas as “patient care areas”:

“ ...

- (a) *basic care area: a patient care area where body contact between a patient and medical electrical equipment is neither frequent nor usual. Examples include
 - (i) *patient examination rooms;*
 - (ii) *patient rooms in a long-term care facility; and*
 - (iii) *patient rooms in general, specialty, and rehabilitation hospitals where body contact between a patient and medical electrical equipment is neither frequent nor usual;**
- (b) *intermediate care area: a patient care area where body contact between a patient and medical electrical equipment is frequent or normal. Examples include
 - (i) *wards and treatment and examination rooms in general, specialty, and rehabilitation hospitals;*
 - (ii) *renal dialysis units;*
 - (iii) *areas for non-invasive electrodiagnosis (ECG, EEG, EMG);*
 - (iv) *patient preparation areas;*
 - (v) *physiotherapy departments;**

- (vi) ultrasound suites;*
 - (vii) dental clinics;*
 - (viii) chiropractic clinics;*
 - (ix) physicians' offices; and*
 - (x) patient bedrooms; and*
- (c) critical care area: a patient care area where the induction and maintenance of general anaesthesia routinely occurs in connection with the examination or treatment of patients, or where cardiac contact between a patient and medical electrical equipment is frequent or normal. Examples include*
- (i) angiographic laboratories;*
 - (ii) cardiac catheterization laboratories;*
 - (iii) cardiac care units;*
 - (iv) emergency trauma units;*
 - (v) intensive care units;*
 - (vi) intensive care neonatal units;*
 - (vii) operating rooms; and*
 - (viii) burn units."*

If your facility falls under any of the above noted uses, Z32 design and testing is likely required.

Z32 testing is typically performed on all receptacles and circuits serving the patient care areas. Receptacles outside of the patient care areas (ie. corridors, staff rooms, receptions, etc.) are usually not included as part of the Z32 tests. Contractors should refer back to their designer for specific requirements for installation and testing.

As part of the Z32 testing, 908 Engineering Personnel will perform the following six tests generally in the order presented.

TEST #1: INSULATION RESISTANCE

Using a megohmmeter, the insulation on each current carrying conductor associated with circuits supplying receptacles in patient care area is tested. The megohmmeter applies a high voltage supply (500VDC) to the conductor and measures the insulation resistance in Ohms (Ω). This test is performed at the breaker box. The ground side of the meter is connected to the ground bus bar and the live (hot) side of the meter is applied to the line and then the neutral circuit conductors. The measured insulation resistance is recorded and compared to the acceptable range.

Contractor Preparation:

In preparation for this test, contractors are asked to:

- remove the breaker box cover(s)
- identify all circuits and circuit conductors supplying receptacles in patient care areas
- remove the neutral conductors from the ground bus bars and leave hanging
- if applicable, remove all ground fault interrupters (GFI) from the circuits to be tested
- ensure that no tools or other devices are plugged into receptacles to be tested

Equivalent Test Circuit: (N/A)

Test Apparatus:

- Fluke 1587 Insulation Digital Multimeter (2012)
 - $\pm (1.5\% + 5 \text{ counts})$ accuracy
 - 0.1M Ω resolution
 - 0 – 2G Ω range

Acceptance Criteria:

- not less than 10k Ω for the neutral conductor
- not less than 500k Ω for the line conductor.

Code Reference:

CSA Z-32-09: 5.3.2

TEST #2: CIRCUIT BREAKERS – MECHANICAL OPERATION and IDENTIFICATION

Each circuit breaker supplying receptacles in patient care areas is switched on and off at least 3 times to verify proper mechanical operation. The panel label and panel directory are also checked for completeness and accuracy.

Contractor Preparation:

In preparation for this test, contractors are asked to:

- identify and label all circuit breakers supplying receptacles in patient care areas
- ensure that no tools or other devices are plugged into receptacles to be tested

Equivalent Test Circuit: (N/A)

Test Apparatus: (N/A)

Acceptance Criteria:

- The breaker successfully makes and breaks the connection on each switch cycle
- The panel is labelled correctly and uniquely
- The panel directory is complete, accurate and accessible

Code Reference:

CSA Z-32-09: 5.5, 5.7.3, 5.7.4, 5.7.5

TEST #3: RECEPTACLE LABEL, COLOUR, GRADE, RETENTIVE FORCE and POLARITY

Each receptacle in patient care areas will be noted for their label, colour, and grade. Corresponding circuit breakers are then switched to ensure circuit labels are correct. Each blade of each receptacle is then individually tested using a specialty force gauge to determine if the mechanical retention is within acceptable limits. Lastly each receptacle is subjected to a simple Line – Neutral – Ground polarity test to determine if each wire has been connected properly.

Contractor Preparation:

In preparation for this test, contractors are asked to:

- permanently install and label all receptacles in patient care areas excluding cover plates
- ensure that no tools or other devices are plugged into receptacles to be tested

Equivalent Test Circuit: (N/A)

Test Apparatus:

- Standard generic incandescent receptacle polarity checker (TENMA 72-6862 or similar)
- SafePlug Electrical Retention Tester (Model 1700, calibrated daily)

Acceptance Criteria:

- Receptacle label should include the circuit number and panel board
- Receptacle label shall be placed in a position where it is visible when the cover plate is in place, not likely to be painted over, and not placed on the cover plate itself
- Only plugs fed from an essential electrical system (ie. backup power) shall be red
- All receptacles shall be hospital grade and identified by a green dot on the face
- Ground pin retentive force shall be not less than 1.1N
- Each individual ungrounded blade retentive force shall not be less than 2.2N
- The combined two ungrounded pin retentive force shall not be less than 13N
- The live conductor shall be connected to the brass screw and the neutral conductor shall be connected to the silver screw. The bare bonding conductor shall be connected to the green / bare ground terminal

Code Reference:

CSA Z-32-09: 5.6.2, 5.6.5, 5.6.6

Canadian Electrical Code (CEC) 24-106 (5) & (6)

TEST #4: VOLTAGE DROP TEST UNDER LOAD

Each receptacle in patient care areas is placed under a temporary load of 80% of the circuit breaker rating (12A on 15A circuits and 16A on 20A circuits). The loaded and unloaded voltages are recorded and a percentage voltage drop is calculated. The voltage drop percentage is then compared to the maximum allowable voltage drop as called for in the CEC.

Contractor Preparation:

In preparation for this test, contractors are asked to:

- permanently install all receptacles in patient care areas excluding cover plates
- ensure that no tools or other devices are plugged into receptacles to be tested

Equivalent Test Circuit:

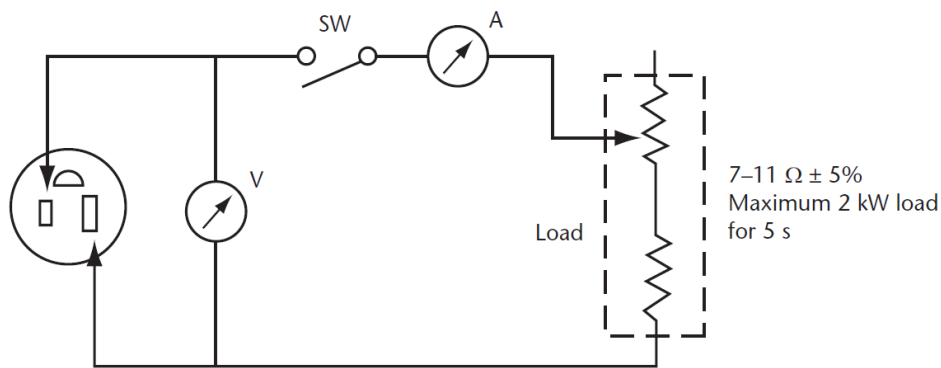

Test Apparatus:

- Voltmeter (V) – Fluke 1587 True RMS Digital Multimeter (2012)
 - $\pm (2\% + 3 \text{ counts})$ accuracy
 - 0.1 mV resolution
 - 0 – 1000V range
- Ammeter (A) – Fluke 375 True RMS AC/DC Clamp Meter (2012)
 - $2\% \pm 5 \text{ counts}$ accuracy
 - 0.1 A resolution
 - 0 – 600A range

Acceptance Criteria:

- Voltage drop shall not exceed 5% of the unloaded voltage (3% preferred)

Code Reference:

CSA Z-32-09: 5.4.3

Canadian Electrical Code (CEC) 8-102

TEST #5: GROUND RETURN PATH VOLTAGE RISE

Under no load, the ground to neutral voltage of each receptacle is measured and compared to the maximum allowable voltage difference by code. Also unloaded, the ground terminal to a local ground reference point is measured and compared to the maximum allowed voltage difference allowed by code. The ground to neutral terminal of each receptacle is then placed under a temporary load of 80% of the circuit breaker rating (12A on 15A circuits and 16A on 20A circuits). Under load, the voltage of the ground terminal to the local ground reference point is measured and compared to the maximum loaded voltage rise permitted by code.

Contractor Preparation:

In preparation for this test, contractors are asked to:

- permanently install all receptacles in patient care areas excluding cover plates
- ensure that no tools or other devices are plugged into receptacles to be tested

Equivalent Test Circuit:

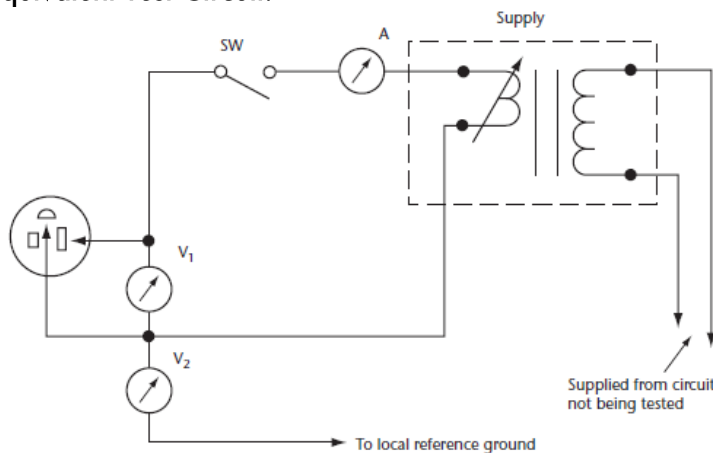

Test Apparatus:

- Voltmeter (V1 and V2) – Fluke 1587 True RMS Digital Multimeter (2012)
 - $\pm (2\% + 3 \text{ counts})$ accuracy
 - 0.1mV resolution
 - 0 – 1000V range
- Ammeter (A) – Fluke 375 True RMS AC/DC Clamp Meter (2012)
 - $2\% \pm 5 \text{ counts}$ accuracy
 - 0.1A resolution
 - 0 – 600A range

Acceptance Criteria:

- Unloaded voltage V1 shall be less than 2V
- Unloaded V2 shall be less than 20mV
- Loaded V2 shall be less than 3V

Code Reference:

CSA Z-32-09: 5.9, 5.10.2

TEST #6: EXPOSED METAL PARTS BONDING VERIFICATION

All metal parts installed within the patient care environment should be bonded to ground. This includes all electrical boxes, communication boxes, metal sinks, plumbing, medical gas lines, air / vacuum lines, light fixtures, air vents, etc.. Firstly, using the local ground reference as a base, continuity to ground is confirmed with an ohmmeter. Secondly, the voltage difference between the ground reference and the measurement point is measured and compared to the maximum allowed by code.

Contractor Preparation:

In preparation for this test, contractors are asked to:

- completely install all bonding to all equipment in the patient care area
- remove cover plates including voice / data / CATV outlets in the patient care area

Equivalent Test Circuit: (N/A)

Test Apparatus:

- Voltmeter – Fluke 1587 True RMS Digital Multimeter (2012)
 - $\pm (2\% + 3 \text{ counts})$ accuracy
 - 0.1 mV resolution
 - 0 – 1000V range
- Ohmmeter – Fluke 1587 True RMS Digital Multimeter (2012)
 - $\pm (0.9\% + 2 \text{ counts})$ accuracy
 - 0.1 Ω resolution
 - 0 – 50M Ω range

Acceptance Criteria:

- All exposed metal parts within the patient care area should have full continuity to ground
- The voltage difference from the ground reference shall be less than 20mV

Code Reference:

CSA Z-32-09: 5.9